

ADA-100 Battery Backup Riser Diagram

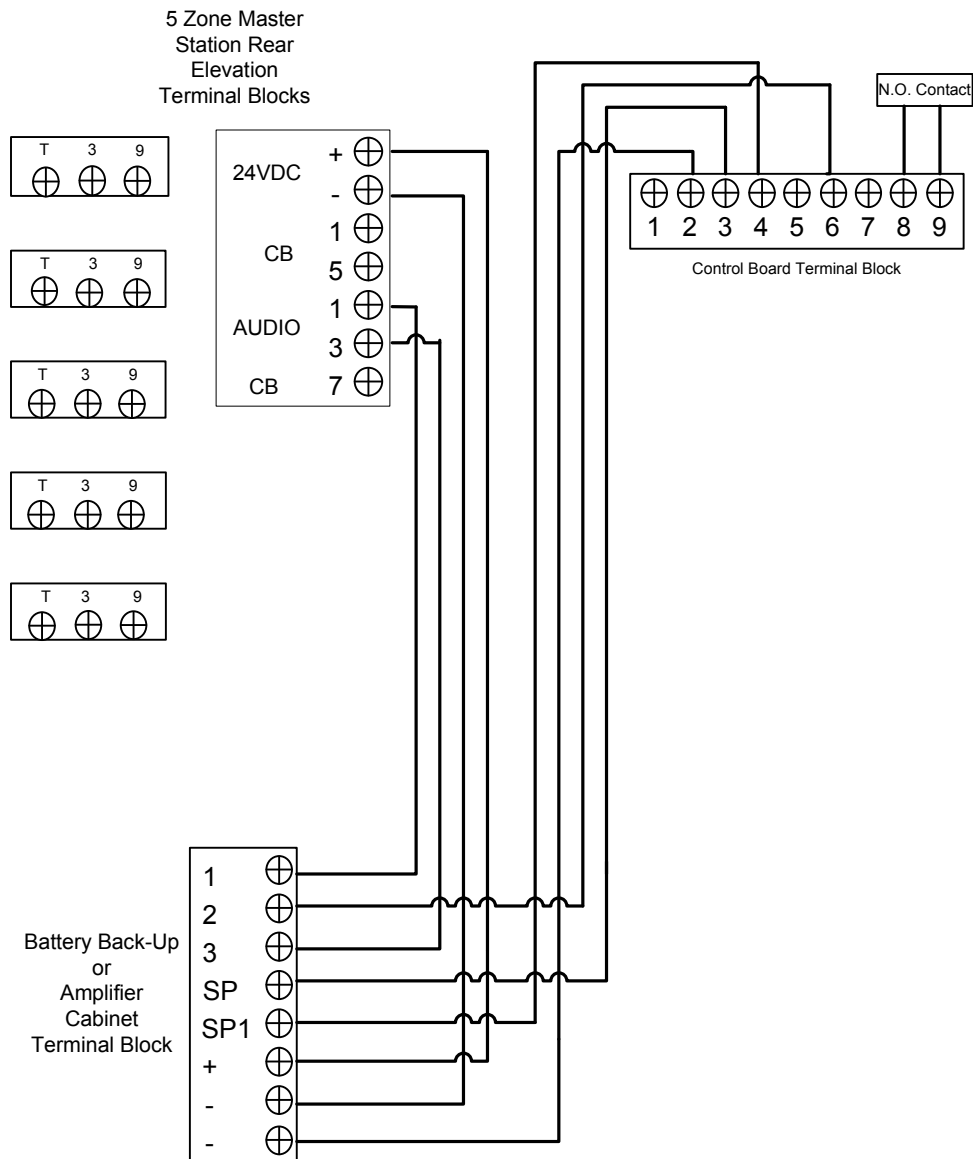

Connect 110 Vac
to the tri volt step down transformer
for battery back-up connection

Connect 24 Vdc from the Altronix
300 ULX to + and - on the terminal
block for amplifier cabinet
connection